



# Fitting Instructions for ROOFTRAK - IFP-BW Integrated Fixing Point For use on warm roof constructions



Tel 0845 0098 980  
Fax 0845 6588 980  
Email [info@nicholsonsts.com](mailto:info@nicholsonsts.com)  
Web [www.nicholsonsts.com](http://www.nicholsonsts.com)

# integrated fixing point **ROOFTRAK™**

A low profile anchor point providing support and wind uplift resistance which can be integrated into most roofing systems when supplied pre-fitted with the appropriate roofing membrane. The IFP-BW is suited mainly to new build applications, but can be retrofitted if required.

Compatibility with the underlying roof system is ensured by using the IFP-BC fitted with a compatible material to the roof system it is being fitted to.

The multiple fixing holes allow a quantifiable uplift resistance to be calculated and the fixing plate will support the loading according to insulation manufacturers compression figures.

Typical uses include

Balustrade fixing

*2no stainless steel fixing point 33mm high x 76mm Ø with  
2no M10 threaded anchorage points*

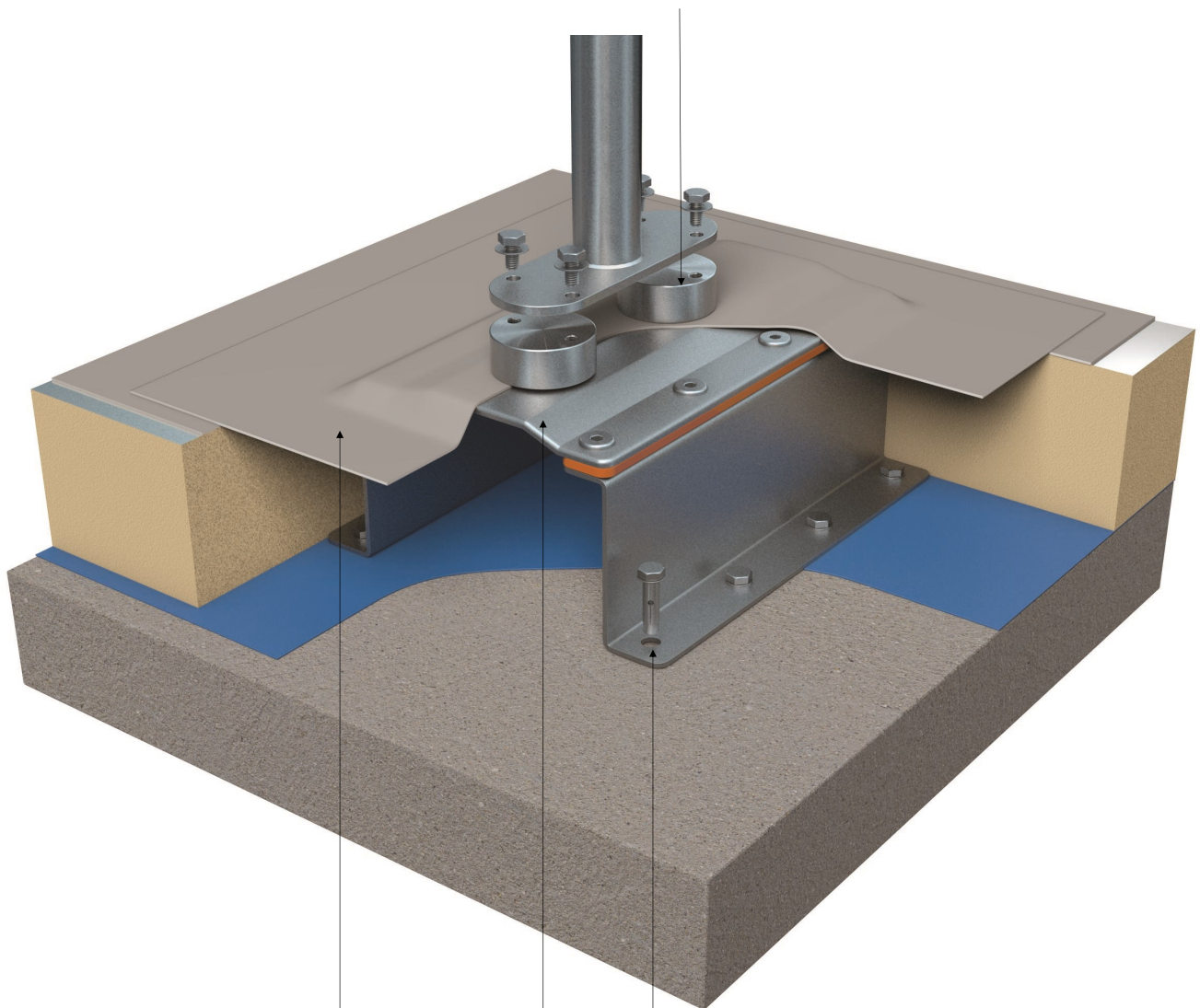

*SBS, bituminous or all types of single ply roofing  
membrane can be fitted to order*

*8no. 8mm Ø fixing holes for direct fixings to substrate*

*225mm x 375mm x 3mm fixing plate*



# integrated fixing point ROOFTRAK™

- 1) **Use;** The IFP2-BW fitting is designed to be fitted over the finished roof surface to provide a fixing point that is completely weatherproof. It can be used in a horizontal or vertical plane and should be installed with the anchor point visible.
- 2) **Setting out;** Mark out positions of each IFP-BW fixing plate prior to installing. Ensure that the two stainless steel anchor points run perpendicular to the run of balustrade and that the M10 anchor points to the top surface of each fitting aligns with the structure or fixing holes in the brackets or posts that will be fitted to the IFP-BW fittings. The anchor points are off centre in the length of the fixing plate, the longer section of plate should be positioned to the inside of the balustrade run.
- 3) **Fixing;** Use all of the available fixing holes to secure the IFP-BW to the roof deck.
- 4) In warm roof situations the fixings should be of an appropriate type and length for the roof deck being used.
- 5) **Weathering;** Once IFP-BW unit is secured to the roof deck, the warm roof insulation can be laid on the roof deck and up to and around the IFP-BW. The roofing membrane can then be installed, ensuring that it runs under the membrane flange which is pre-attached to the IFP-BW. Finally the membrane flange overlap to the roof finish that extends past the fixing plate should be joined to the roof finish in accordance with the roofing system manufacturers instructions and guide.
- 6) Check the flange overlap seal to ensure that a totally waterproof joint is made.

## **WARNING**

Health & Safety; Ensure that adequate measures are taken to warn pedestrian traffic of possible trip hazards. These measures would include notifying all personnel using the immediate area, the site safety officer and site agent.

Provision should be made for thermal expansion and contraction of any system attached to the Rooftrak IFP-BW to ensure that undue lateral stress is not imposed on the fitting.

The Rooftrak-IFP-BW should not be disassembled, adapted, adjusted and under no circumstances should the top part be turned or twisted once the base plate is fixed. Any such actions will indemnify the Nicholson warranty. No liability for failure will be accepted.

For further technical support please contact the technical team 0845 0098 980 or [technical@nicholsonsts.com](mailto:technical@nicholsonsts.com)



**CAUTION**

**Trip Hazards on this roof –  
proceed with care!**

Place this warning notice in an appropriate position to warn operatives *before* accessing the roof area