



Fitting Instructions for IFP– GR Integrated Fixing Point for Green Roof Systems



Tel 0845 0098 980
Fax 0845 6588 980
Email info@nicholsonsts.com
Web www.nicholsonsts.com

integrated fixing point **ROOFTRAK™**

ROOFTRAK-IFP/GR Green Roof

A deep profile anchor point providing support and wind uplift resistance which can be integrated into most green roofing systems when supplied pre-fitted with the appropriate roofing membrane. The IFP is suited to retrofit and new build applications. Compatibility with the underlying roof system is ensured by using the IFP fitted with a compatible material to the roof system it is being fitted to. The multiple fixing holes allow a quantifiable uplift resistance to be calculated and the fixing plate will support the loading according to insulation manufacturers compression figures.

Typical uses include

- solar panels
- solar array frames,
- roof top plant
- air conditioning unit supports
- unistrut frames
- cable and services trays

Factory fitted membrane flange to be as per the field membrane of the roof

*Stainless Steel fixing point
Including 2no. female M10
threads.*

*Support post upstand
manufactured to suit depth
of roof build up.*

*IFP 300mm x 300mm x 3mm fixing and support plate
IFP-C 200mm x 170mm x 3mm fixing and support plate*

17mm & 8mm Ø fixing holes for thermally broken and self drilling roofing fixings

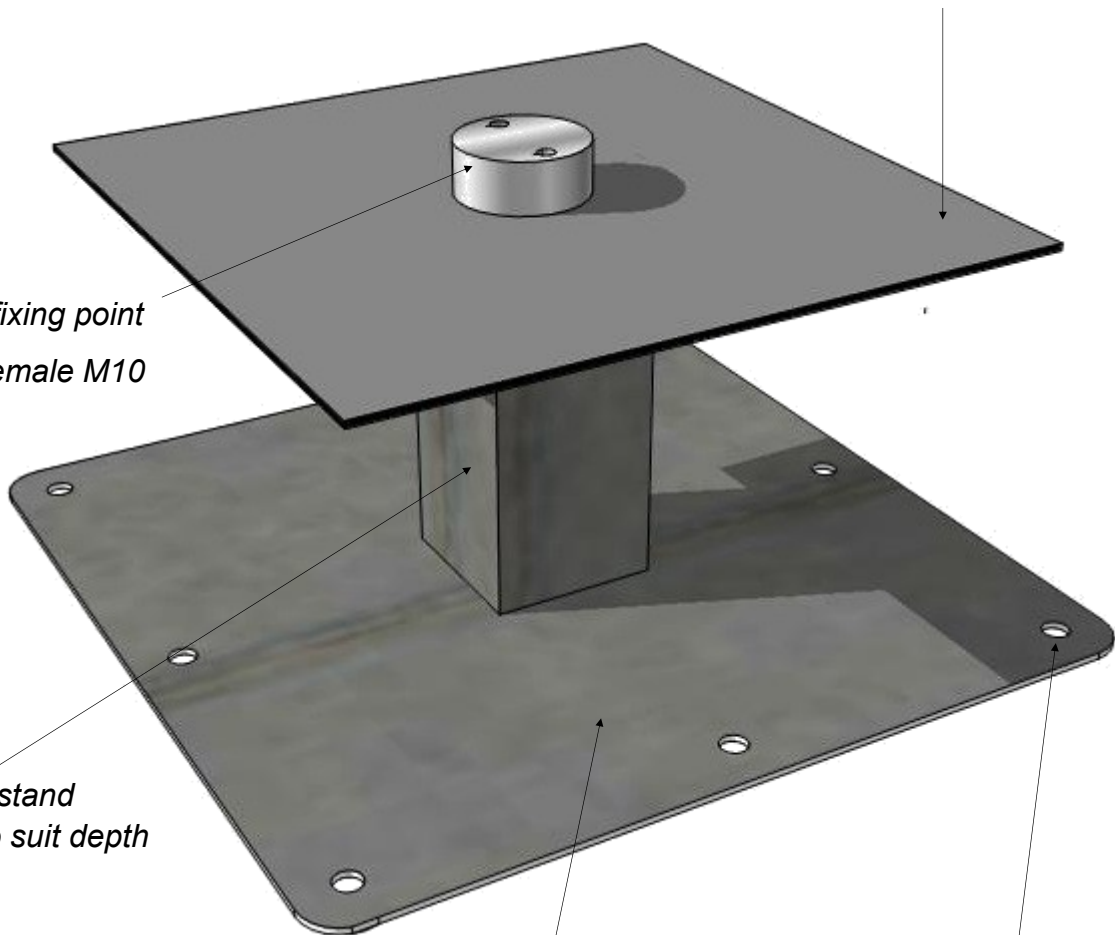

integrated fixing point **ROOFTRAK™**

Use; The IFP fitting is designed to be integrated with the finished roof surface to provide a fixing point that is completely weatherproof. It can be used in a horizontal plane and should be installed with the anchor point visible above the green roof build up. Where retro fitting to an existing roof it can be supplied with a matching cap sheet or underlay. Where supplied with a bitumen base sheet this should be always covered with the appropriate cap sheet.

Setting out; Mark out positions of each IFP fixing plate prior to installing. Ensure that the M10 anchor points to the top surface of each fitting aligns with the structure or fixing holes in the rails that will be fitted to the IFP fittings.

Fixing; Taking into account the uplift forces that will be imposed on the fitting use appropriate fixings in as many of the holes in the fixing plate are required to achieve the desired uplift figure. A minimum of six fixings per unit should be used.

There are two sizes of hole (8mm & 17mm sized holes) for either thermally broken or direct fixings back to the structure. In warm roof applications appropriate length fixings should be used to penetrate the insulation and into the roof deck. Where a steel roof deck is present fixings should be into the crowns of the profile and not located in the troughs. In cold roof situations the fixings should be of an appropriate type and length for the roof deck being used.

Weathering; Once IFP/GR unit is secured to the roof deck, the flange sheet should be sealed to the membrane roof. This should be carried out in accordance with the manufacturer's instructions and guidance and in some cases may need to be carried out by a membrane manufacturer approved contractor Check that a totally waterproof joint is made.

Health & Safety; Ensure that adequate measures are taken to warn pedestrian traffic of possible trip hazards. These measures would include notifying all personnel using the immediate area, the site safety officer and site agent. The warning sign attached should be placed in an appropriate visible location *before* access to the roof is gained.

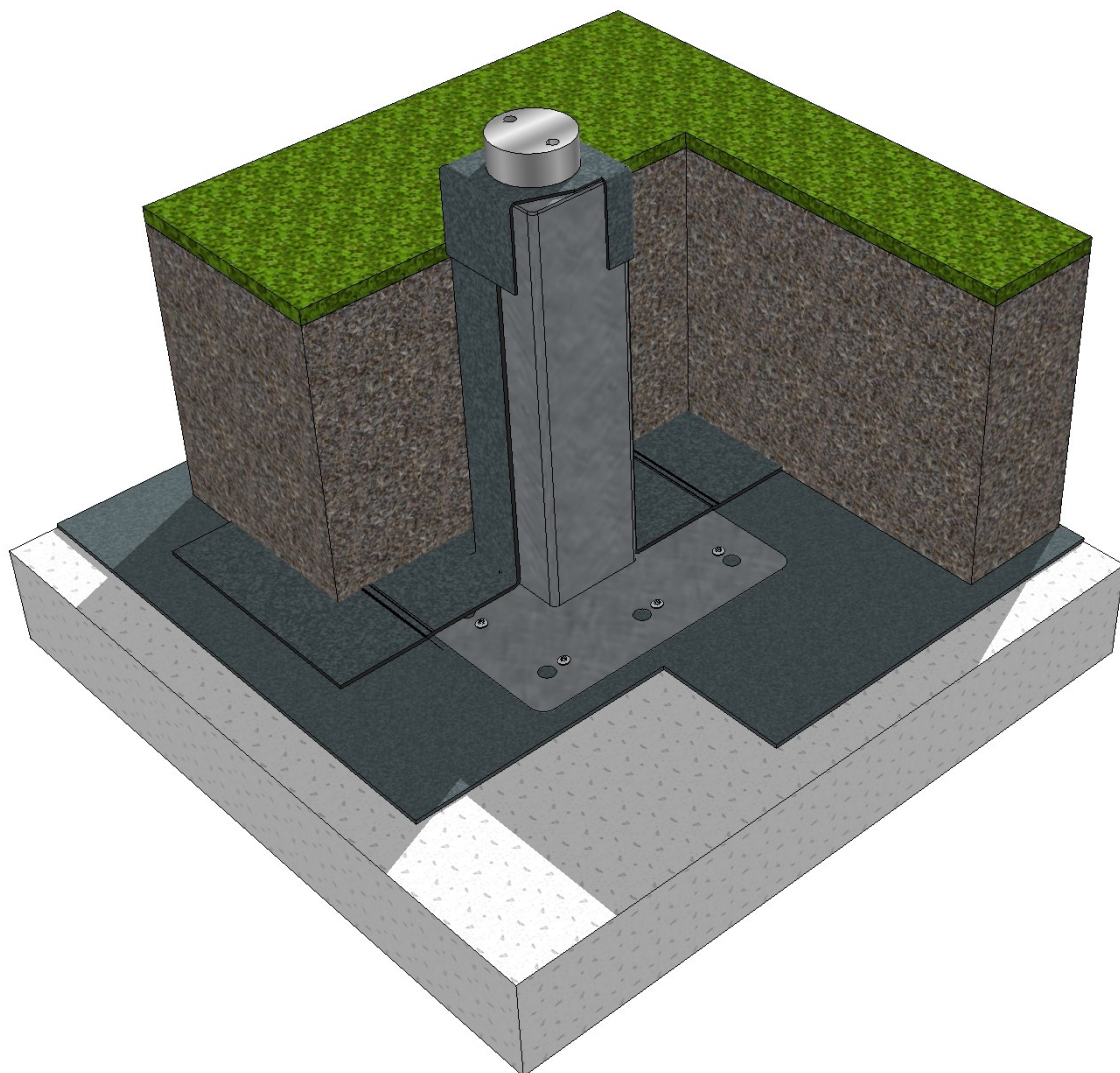



integrated fixing point

ROOFTRAK™



CAUTION

**Trip Hazards on this roof –
proceed with care!**

Place this warning notice in an appropriate position to warn operatives *before* accessing the roof area