

# Series M5 ROOFBOX Installation Instructions

Installation instructions to be read in conjunction with Drawing M5 M-000/5 /6 (1000h or 1500h) and other Detail Drawings as below -

Insulation options Mineral Wool 50/100 or PIR 50 M-0009 Upstand Detail K Series Kerb M-0010 Upstand Detail Concrete Kerb

SD-0001 Service Penetrations SD-000/2 /3 Typical Universal Duct Spigot SD-000/4 /5 Typical One Piece Circular Spigot

SD-000/6 /7 Typical Two Piece Circular Spigot WH-000/2 /1 Typical Weathering Hood/ with Underhood



## Health & safety considerations

- As with all roof work, beware of falls from height and have a management agreed plan of works.
- Make sure any roof openings are protected to prevent persons or tools falling .
- All relevant PPE including fall arrest equipment should be used as appropriate
- Do not leave any unfixed parts on the roof during periods of high wind. Assume winds can develop any time
- Two persons or more may be required to lift the frame safely

**At no time should Roofboxes be used for personnel access - appropriate working platforms should be in place at all times**

# General notes regarding fixings and accessories

- Fixing packs are supplied for each riser location and are labelled separately. These contain everything required to fix the frames to the kerb upstands and the panels to the frames. Fixings are also included for corner flashings and duct spigots.
- Frame bolt set                    2x M10x20/30 bolts  
    2x M10 spring washers
- Brace bolt set                    2x M10x20/30 bolts  
    2x M10 spring washers  
    2x M10 flat washers  
    2x M10 nuts
- Foam sealing tape                10mm wide self-adhesive foam tape is supplied and should be applied to the mating edges of panels.
- Panel fixing screws               75mm long (or to suit increased insulation) self drilling, colour-matched screws
- Accessory fixings                25mm long self drilling, colour-matched screws
- If your Roofbox framework is delivered separately to the Roofbox panels, the fixings will be delivered with the appropriate parts
- Colour matched mastic sealant is supplied, this is for use when fixing duct spigots and for final sealing between panels. All mastics must be used according to the manufacturer's recommendations (including the permitted temperature range) and be compatible with adjacent materials.
- Spare fixing screws of all types are also included in the fixing package
- At no time should Roofboxes be used for personnel access - appropriate working platforms should be in place at all times

# General notes regarding numbering of frame parts

Frame parts are etched with specific information which gives a project reference, a location number and a part number. This formula is shown as follows:



Project reference here

Location no. here

Specific part no. here

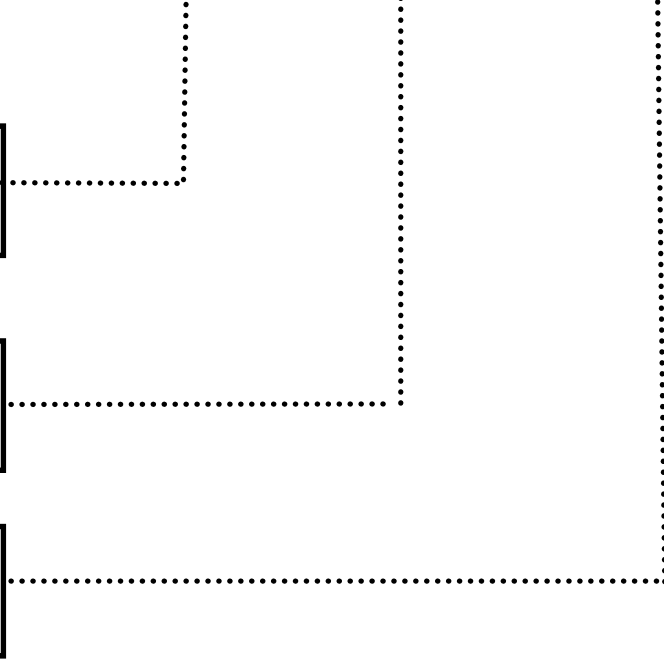

## KERB OPTIONS

Kerbs will normally be in place and will have been sealed within the roof membrane before the installation of the M Series Roofbox commences.  
They would be either– upstands provided by the main contractor and constructed in concrete or timber or similar  
or– Nicholson K Series kerbs

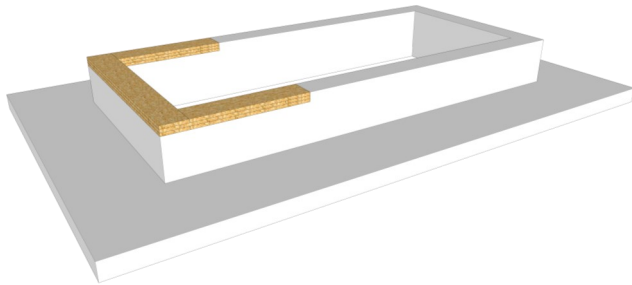

### M.C. Purpose Fabricated Kerbs

The adequacy of the structure of in situ constructed kerbs and their fixings should be verified in advance by the M.C.

150mm minimum width is standard for concrete.

The mastic to be provided to seal between the plinth and the frame should achieve an acceptable standard of airtightness and be durable to sustain the projected life of the Roofbox.

Complete the roof build up and the roof sealing membrane dressing it up and over the kerb.

Roofbox construction can proceed using fixings provided.

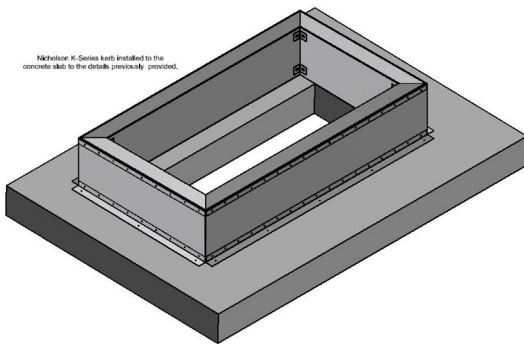

### Nicholson K Series Kerbs

The adequacy of the substructure should be verified in advance by the M.C.

150mm minimum width of structural timbers below the finished decking board and all around the opening is standard for timber roofs.

The mastic to be provided to seal between the roof and the kerb and between the kerb and the frame should achieve an acceptable standard of airtightness and be durable to sustain the projected life of the Roofbox.

Fix down the assembled kerb using appropriate fixings in the holes provided in the lower fixing lip.

Check and adjust so that the top rim of the kerb is in an horizontal plane.

Complete the roof build up and the roof sealing membrane dressing it up and over the kerb.

Roofbox construction can proceed using fixings provided.

## M5 KERB SETTING OUT Part References

KERB HEIGHT OPTIONS ACCORDING TO ORDER

200 / 375 / 450 / 600

KERB PARTS

K5-XX-KA / 1 (x2) / 2 (x2) / 3 (x2)

K5-XX-KC1 (x8) corner brackets

K5-XX-KS1 (x4) straight brackets

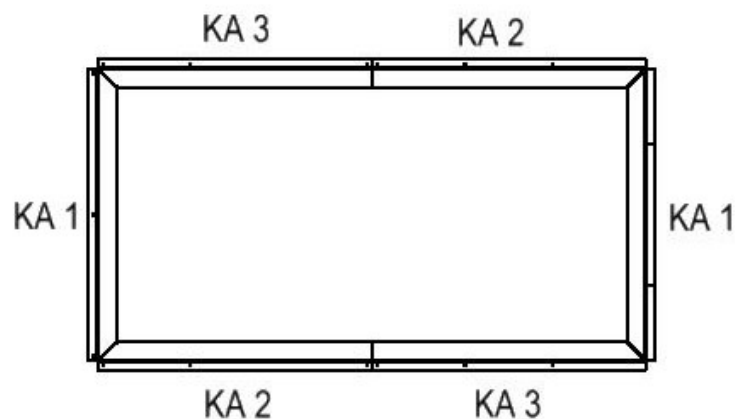

Contractor to verify the structural adequacy of the 3000mm x 1500mm roof opening, in all respects, before installation.

Assemble the kerb parts in locations as shown and establish the kerb top in a level plane.

Roof insulation and roof membrane with upstand dressed over the kerb to be completed by others before frame assembly

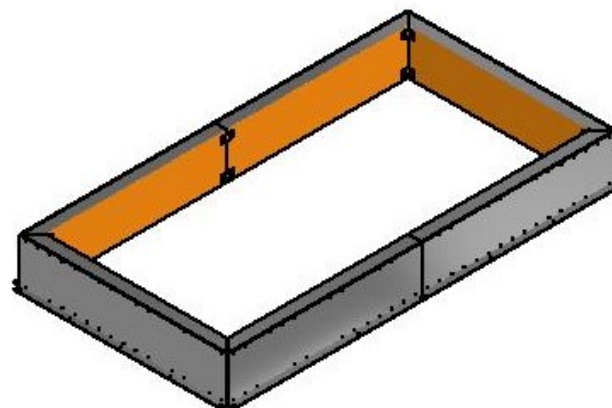

FIXINGS TO TIMBER

DFT-60x45 fix through all predrilled holes

FIXINGS TO CONCRETE

SF-RS-6.1x75 fix through all predrilled holes

FIXINGS OF FRAME PARTS

M10x20/30 c/w nuts and washers as required

## M5 Part references

### SETTING OUT DIMENSIONS

For correct positioning of the frame  
on the kerb / roof penetration

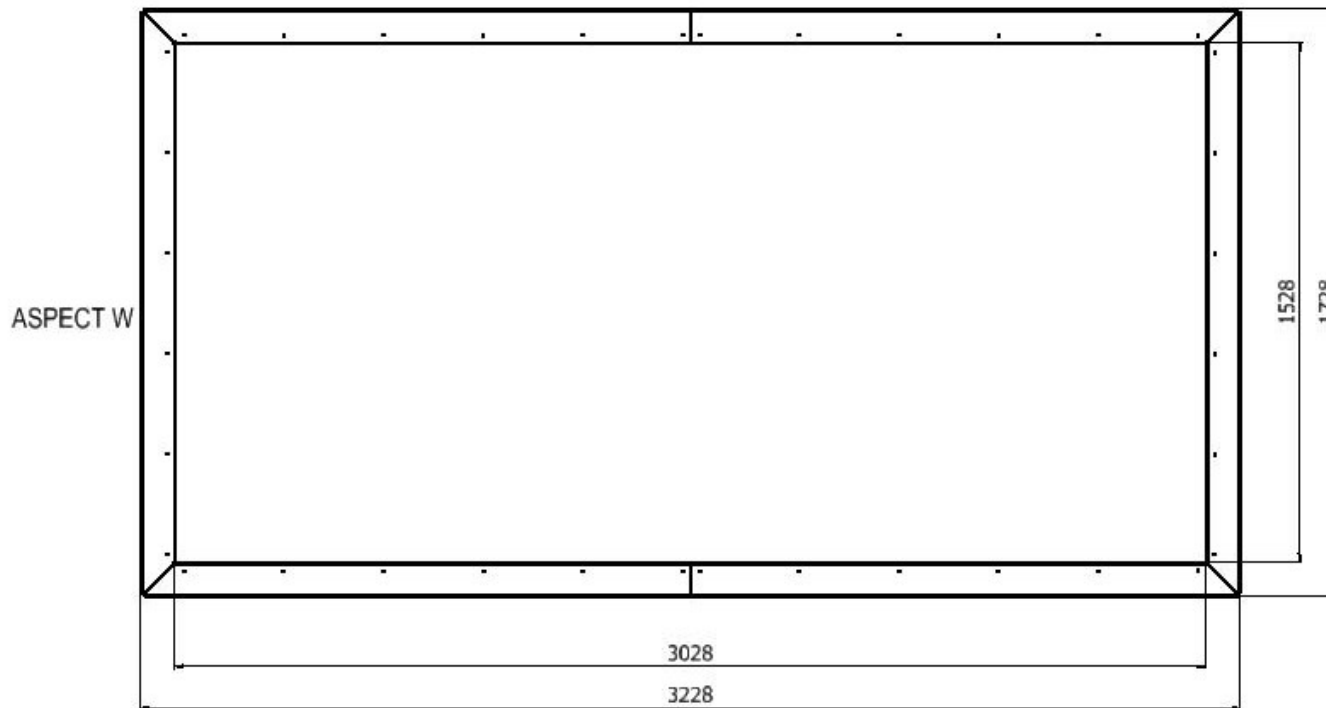

### ORIENTATION

All reference drawings show the  
aspect W for correct assembly.

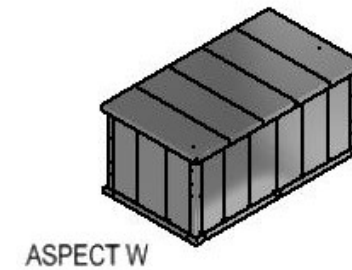

Read in conjunction with drawings  
M-0005 (1000h or 1500h) M5- Typical Plans Sections  
M-0006 (1000h or 1500h) M5- Typical Elevation

## Installing the frame

The frame parts for Roofbox are supplied individually packed, which will be marked according to its location. Where there are multiple Roofbox locations on the same roof, please ensure that you have identified the correction location and have the corresponding frame pack before starting to assemble the frame. A pack of all the necessary fixings is also supplied for each Roofbox location. Please ensure these are stored in a safe place as they will be required when it comes to installing the Roofbox panels.

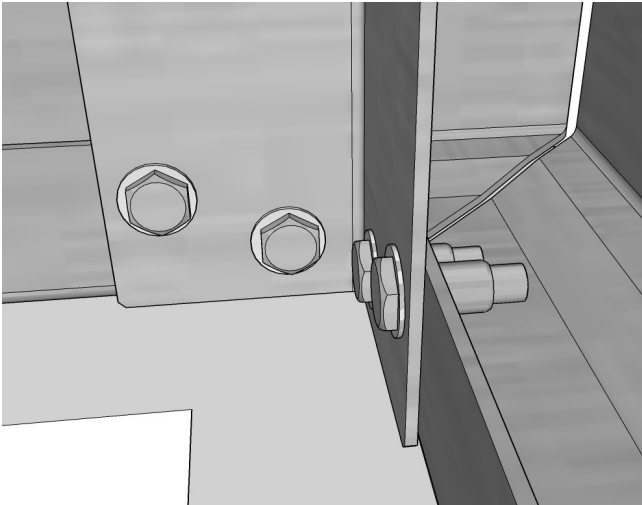

Use the M10 x 20 stainless steel bolts and washers provided and tighten to 42 N/m



All frame parts are etched with their location and part number

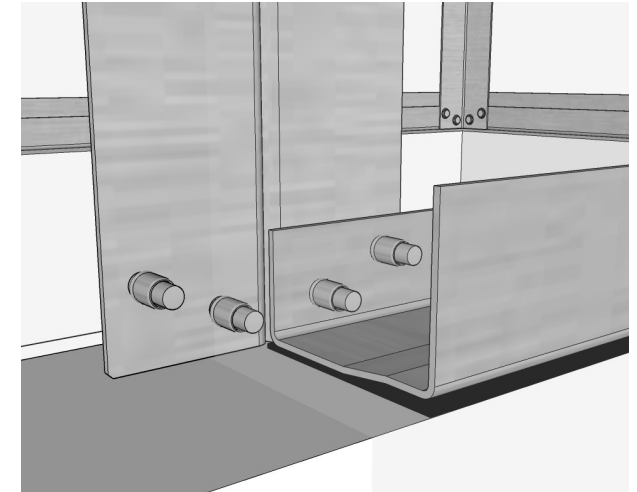

Apply a generous mastic bead between the Roofbox frame and the kerb upstand before fixing down with sufficient and appropriate and adequate fixings. The mastic should achieve an acceptable standard of airtightness and be durable to the projected life of the Roofbox.



## M5 FRAME Part References

### FRAME PARTS

M5-XX-FR /1 (x2)/ 2 (x2)/ 3 (x2)/ 4 (x2)/ 5 / 6 / 7 / 8

M5-XX-CP 1 (x8)

M5-XX-LB 1 (x4)

### AIR SEALING THE ROOFBOX FRAME TO THE UPSTAND

Once the frame is assembled apply the self adhesive tape provided, onto the inside of the channel profile, to seal all the frame base rail gaps at corner mitre joints (and at straight joints if applicable)

Apply mastic seal all around between the kerb and the frame base rails.

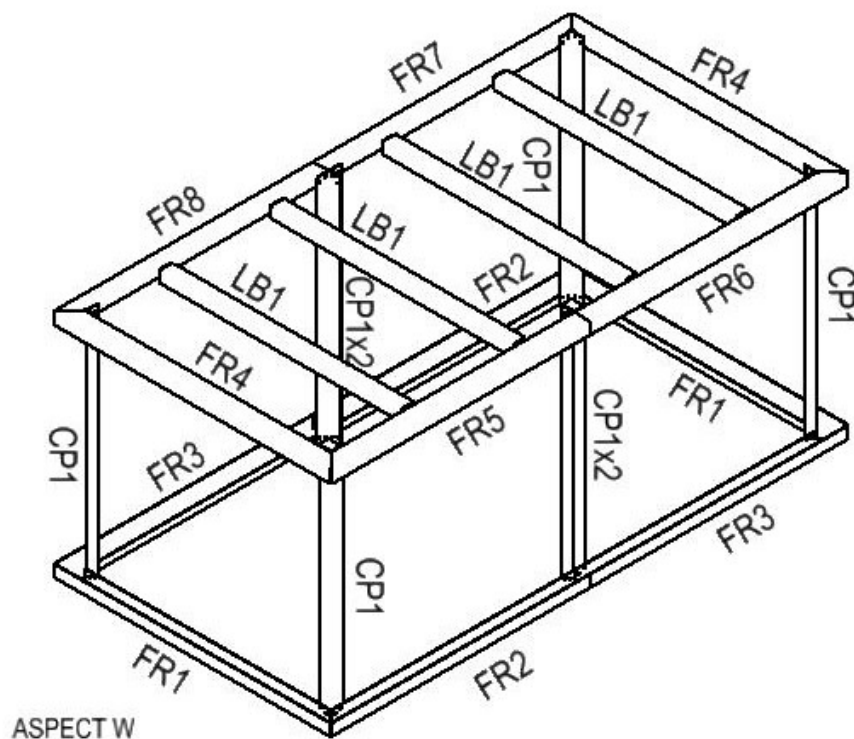

### FIXINGS TO M3 ALUMINIUM KERB TOP

DF3-5.5x35 @ 500mm cs max

FIXINGS TO TIMBER KERB TOP

DFT-60x45 @ 500mm cs max

FIXINGS TO CONCRETE KERB TOP

SF-RS-6.1x75 @ 500mm cs max

FIXINGS OF FRAME PARTS

M10x20/30 c/w nuts and washers as required

Read in conjunction with drawings

M-0005 (1000h or 1500h) M5- Typical Plans Sections

M-0006 (1000h or 1500h) M5- Typical Elevation



## Installing the frame

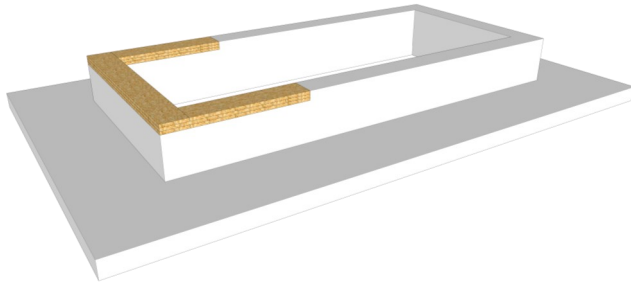

### Step 1

The kerb upstand must be clean and level, and free of obstructions before starting to install the Roofbox framework.

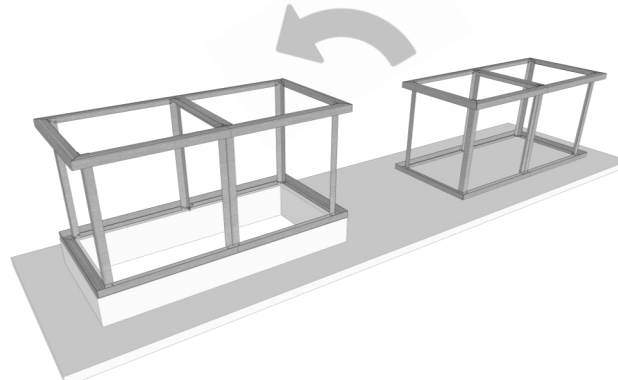

### Step 2

Refer to the specific Roofbox instruction diagram and assemble the frame parts using the bolts supplied. In some cases, it may be easier to do this off the kerb and then lift it on as a complete unit if there is space to do this.

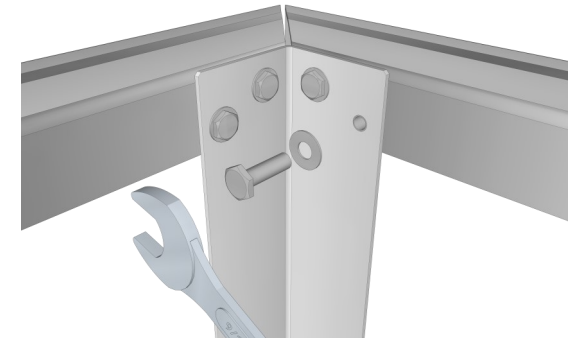

### Step 3

The rails have threaded inserts already installed. Using the M10 x 20 and M10 anti shake washers supplied in the fixings pack, simply bolt the whole assembly together and tighten to 42N-m.



### Step 4

Any braces should be fixed to the frame posts Using the M10 x 20, M10 anti shake washers, M10 flat washers and M10 nuts supplied in the fixings pack. All bolts should be tightened to 42N/m.

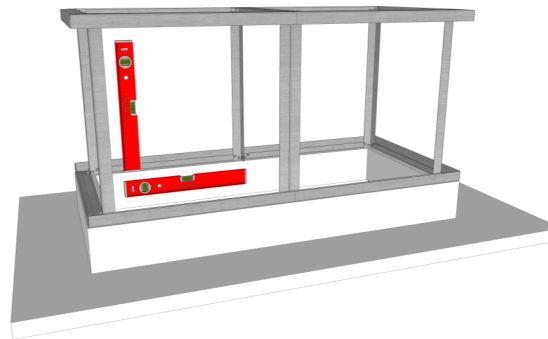

### Step 5

Frames should be fully assembled and levelled before fixing down into the kerb upstand. It may be necessary to use packers to ensure that the frame is installed in a level plane. Gaps at joints between the bottom rails should be sealed with mastic to achieve an acceptable level of air permeability.

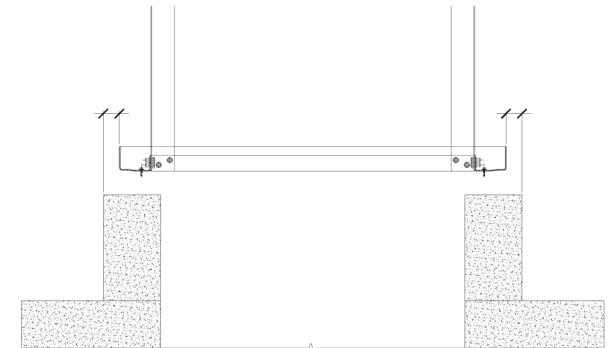

### Step 6

Normally the Roofbox should be centralised on the kerb upstand. However, specific installation instructions for each location may apply and are provided where necessary in the Setting Out Reference Drawing above.

## M5 KERB APRON FLASHING Part References

Flashings M5-XX-DF /1 (x2)/ 2 (x2)/ 3 (x2)/ 4 (x4)  
Overlap design 100mm

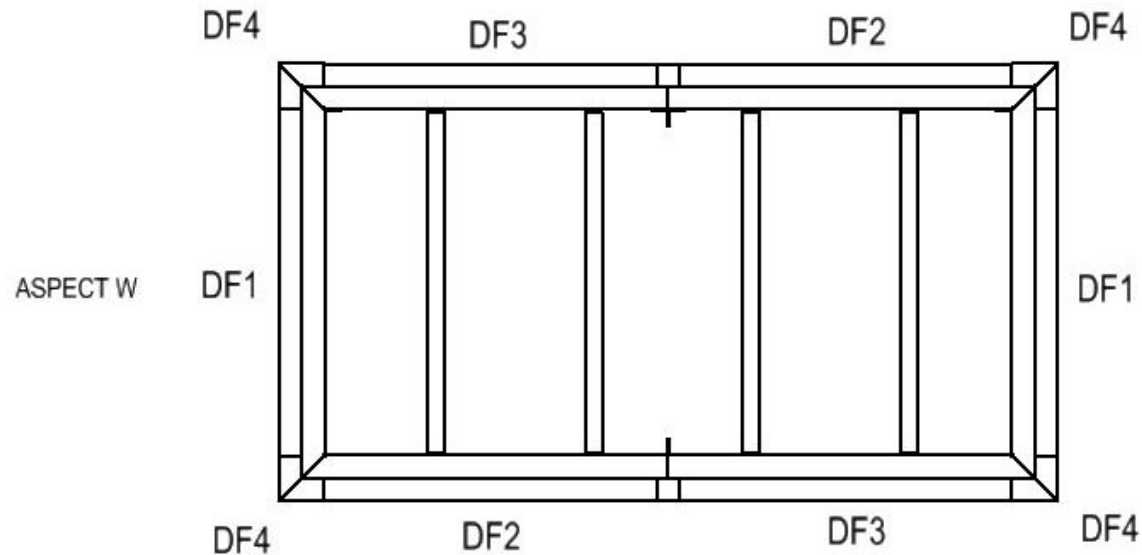

Apply a silicon bead to the vertical face of the frame bottom rail to prevent air penetration between the kerb apron and the frame.

Read in conjunction with drawings  
M-0005 (1000h or 1500h) M5- Typical Plans Sections  
M-0006 (1000h or 1500h) M5- Typical Elevation

FIXINGS TO FRAME DF3-SS-CF-4.8x16  
@ 500 mm cs max

## Installing the apron flashing

A mastic bead should be applied to the vertical face of the frame base rail throughout the complete perimeter to seal for air tightness

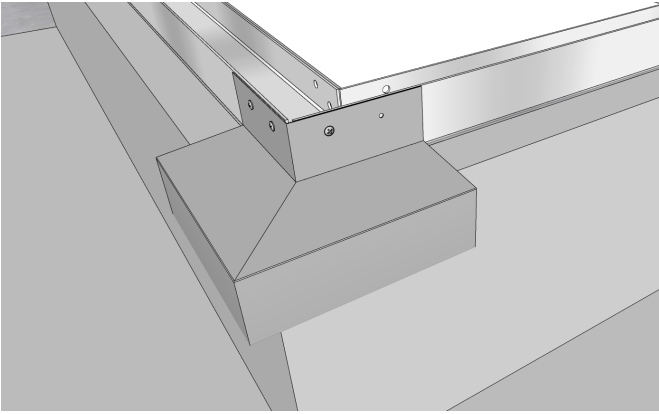

### Step 1

Start by fixing an apron flashing corner piece to the base rail using the 16mm, low profile, self-drilling screws provided. Align the top of the corner piece with the top of the Roofbox rail as shown.

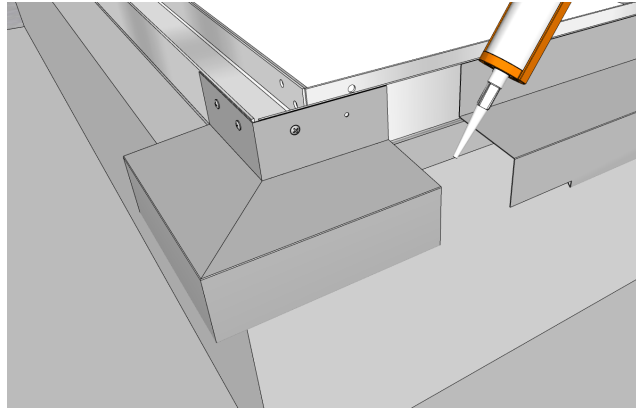

### Step 2

It may be advisable to fit the first apron flashing straight length piece at the same time as the apron flashing corner piece to enable proper alignment of the flashings.

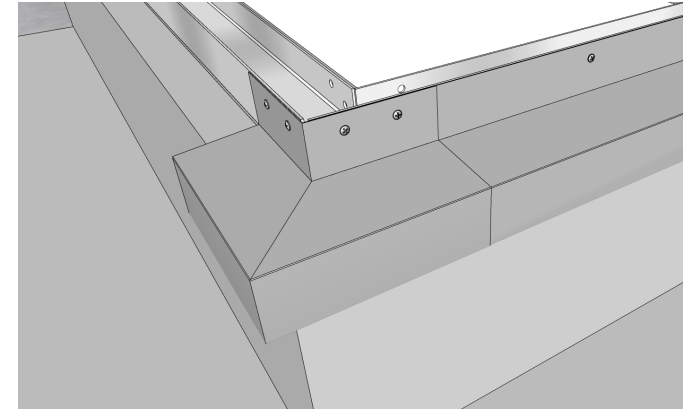

### Step 3

Insert the end of the apron flashing straight piece under the apron flashing corner piece, and use a bead of mastic sealant on the joint to ensure a full weather seal to the detail.

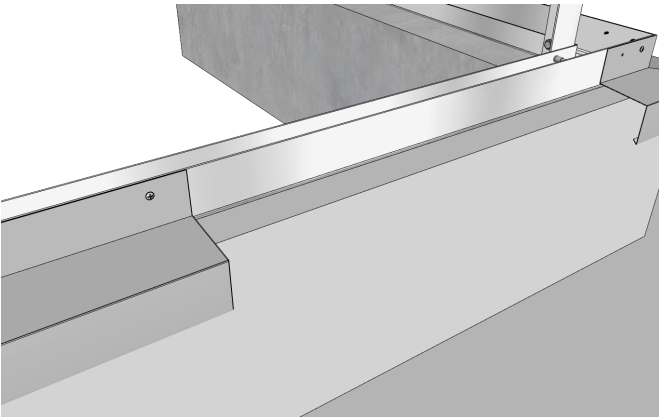

### Step 4

Work along each side of the Roofbox frame, fixing the apron flashing straight pieces in the same way, and keeping the top of the flashing upstand level with the top edge of the bottom rail.

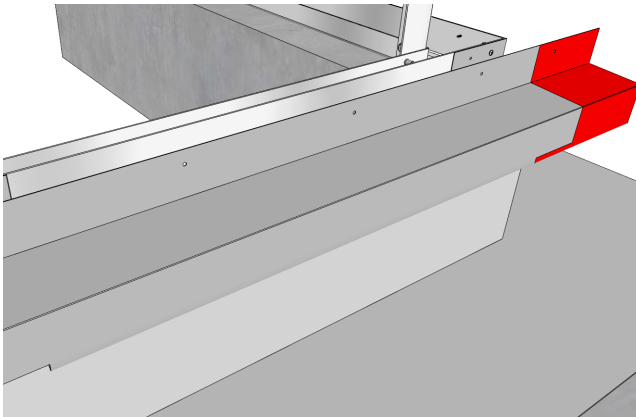

### Step 5

As the next corner is reached, the last apron flashing straight length will need cutting to length. This can be done using a pair of tin snips or a small grinder (the flashing is aluminium, so no sparks are emitted during cutting). Make good cut edges with touch up paint.

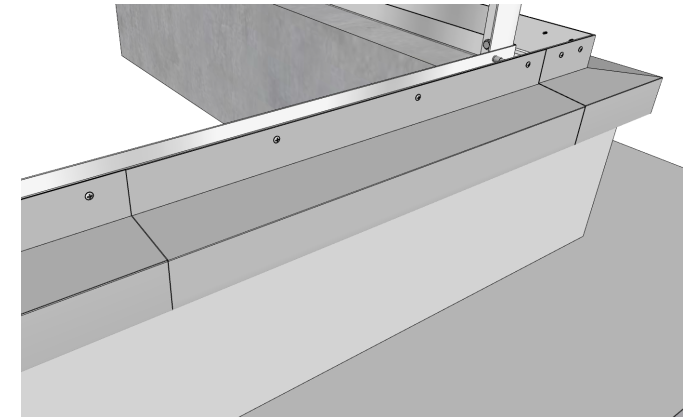

### Step 6

Cut back the drip edge at the bottom of the flashing to allow it to slide under the corner flashing and into the well on the corner flashing. Corner flashings can be left loose until the last straight flashing in a run is fitted. These can then be fixed back to the Roofbox rail once all components are in place.

# M5 PANELS / COVERS Part References

- Panels M5-XX-MPA 1 (x2)/ 2 (x2)/ 3 (x2)/ 4 (x2)/ 5 (x8)/ 6 (x2)
- Cover Flashings M5-XX-CF1 (x4)
- Circular Spigot to order
- Universal Duct Spigot to order
- Hood (cw Underhood) to order
- 5mm gaps between panels

Penetration accessories are listed on the front page but not illustrated. General penetration details are included below. Plot cut-outs so that the integrity of all panels is maintained. For 1000h Roofbox the maximum possible height of any cut-out is 730mm down from 160mm below top of lid (for 50mm insulation). For 1500h Roofbox the maximum possible height of any cut-out is 1230mm down from 160mm below top of lid (for 50mm insulation). Cut panels close (within 5mm) of service penetrations, ensuring 1 degree falls away from the Roofbox for all services. Make good the paint finish to cut edges using an appropriate paint. Apply silicon sealant as necessary to Roofbox penetrations at covers/ spigots/ hoods to prevent air permeability and water ingress.

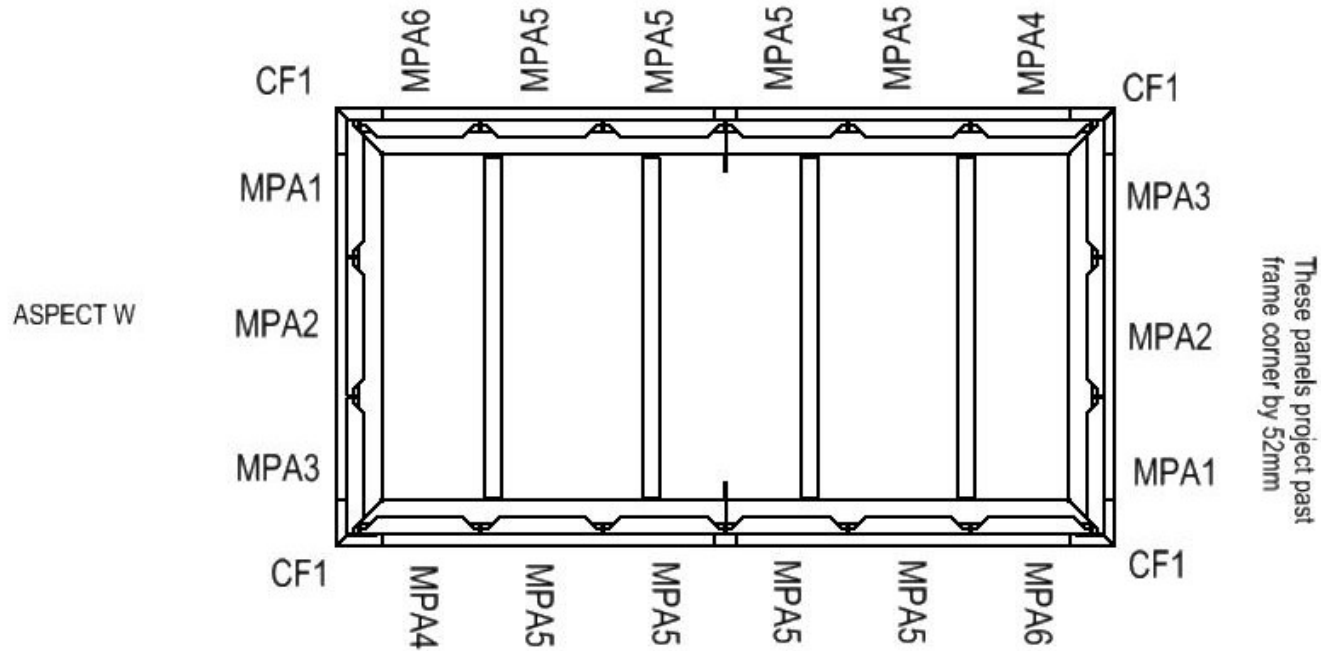

Read in conjunction with drawings  
 M-0005 (1000h or 1500h) M5- Typical Plans Sections  
 M-0006 (1000h or 1500h) M5- Typical Elevation

FIXINGS FOR PANELS  
 DF3-SSA4-PL-HY-S15-5.5x75ppc  
 FIXINGS FOR COVERS  
 DF3-SSA4-PL-S15-5.5x25ppc

## Installing ROOFBOX side panels

Roofbox side panels are supplied in sets for a specific Roofbox location. Where more than one Roofbox is located on a roof, please ensure that you match up the location number with the right set of panels.

Within a set of side panels, the width of the panels may vary and it is important that the correct panels are selected for their specific location on the Roofbox. The location specific installation instructions will advise where each panel goes on the framework. Panels to opposite sides of a Roofbox will often mirror each other.

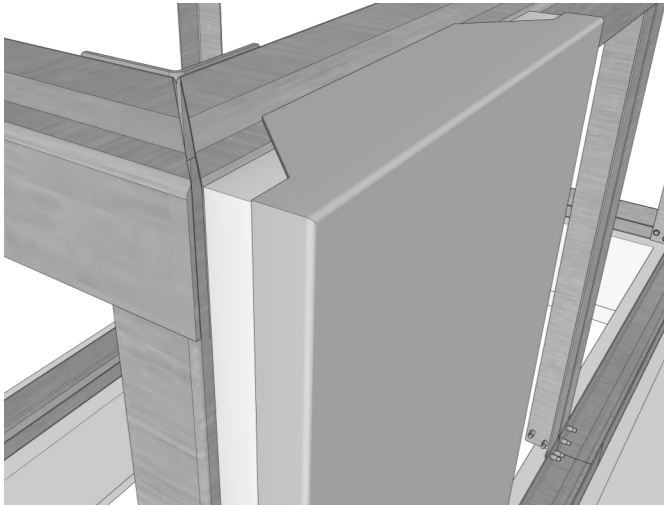

Panels locate in rebate on the top of the frame

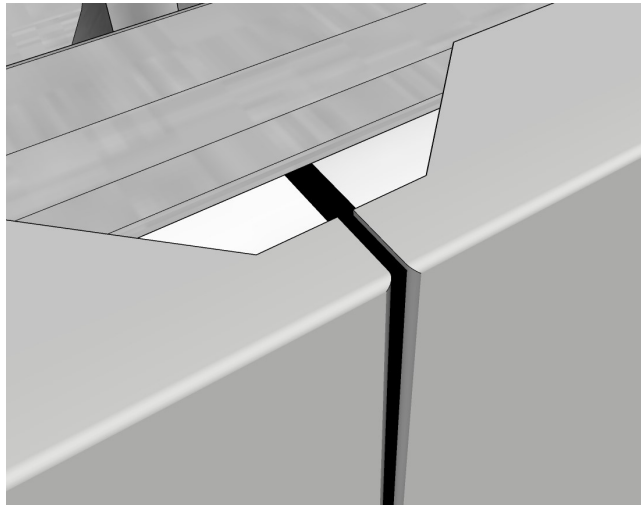

A 5mm gap should be left between panels

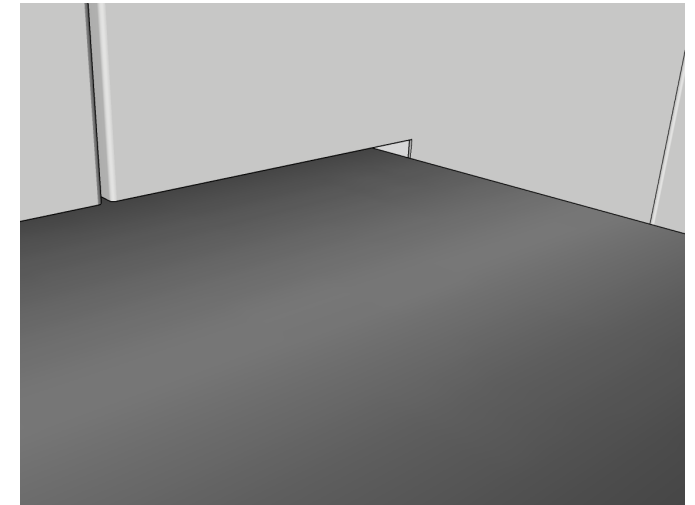

Cut panels around any service penetrations  
Make good cut edges with touch up paint

- Roofbox panels can be cut using standard tooling, including circular saws, jig saws and angle grinders. During cutting, ensure that the panels are well protected to avoid scratching of the panel face during the cutting process.
- Large ducts may have a panel joint positioned to allow cutting less material from two panels, rather than a larger cut out of material from one panel. Where service penetrations require cutting through the full width of a panel, further support to the cut panel may be required to maintain the stability of the surrounding panels.
- Ensure that the panels are vertical and securely located onto the top rail before final fixing to the Roofbox frame.

## Installing ROOFBOX side panels

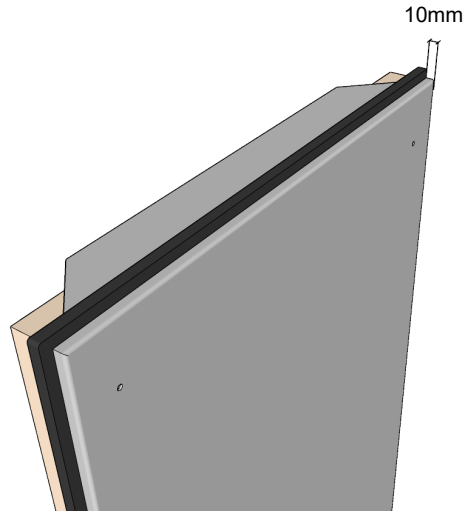

### Step 1

The 10mm compressible foam strip provided should be applied to one side and the top of each panel resulting in all meeting panel edges having the foam filler strip in the joint. Position the foam tape 10mm back from the face of the panel.

With Apron flashing

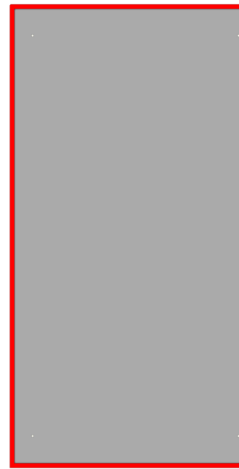

Without Apron flashing

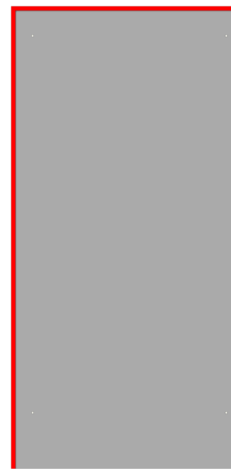

### Step 2

Where apron flashings are used, also apply the foam tape to the bottom edge of each panel.

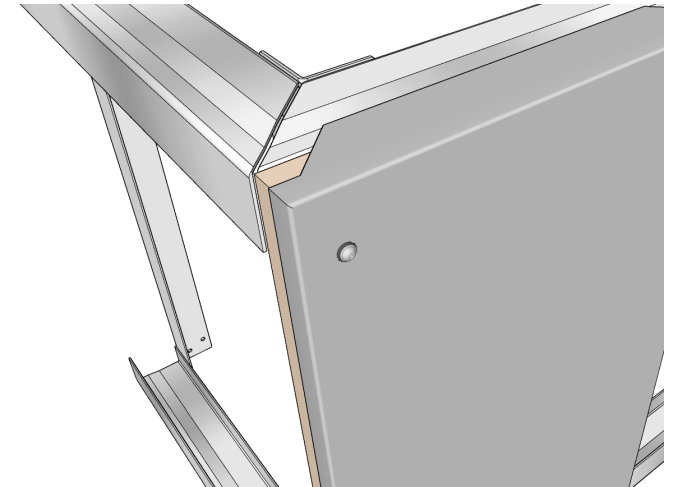

### Step 3

Line up the edge of the first panel with the corner of the framework as shown.

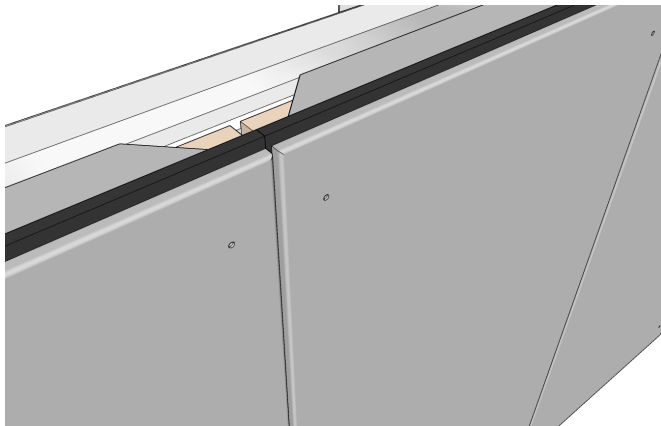

### Step 4

Panels should be placed in position using the lip on the top edge to locate them at the right height. A 5mm space should be left between each panel. Use a 5mm packing piece to separate the panels during the installation process, this gap will be sealed with a mastic joint later on.

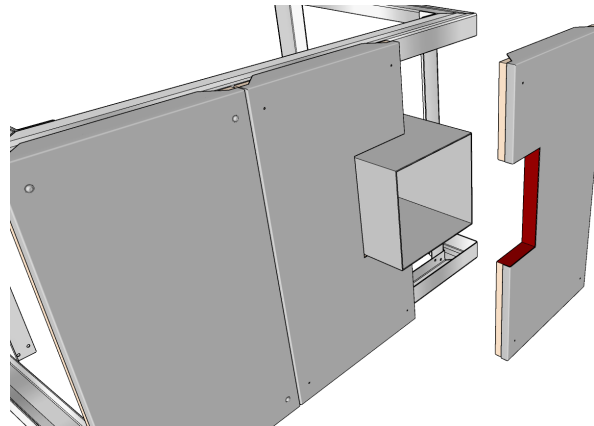

### Step 5

If the panels require cutting around a service penetration, carefully mark and cut the panels in accordance with the instruction in the next section leaving a 5mm margin around the duct or pipe.

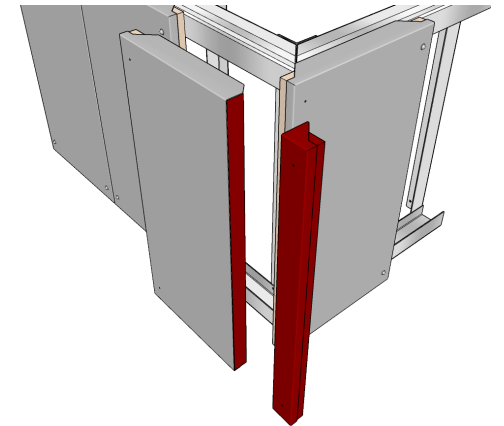

## Installing ROOFBOX side panels

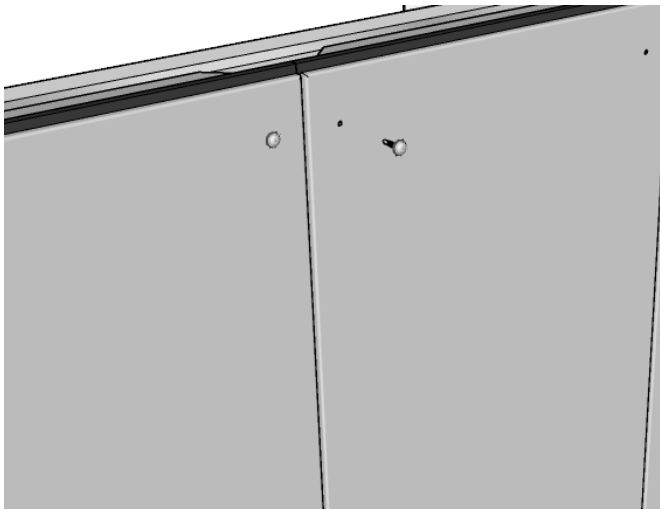

### Step 7

Once the panels are properly positioned they should be fixed to the frame through the pre-drilled holes using the self-drilling, self-sealing fixings supplied in the fixing pack.

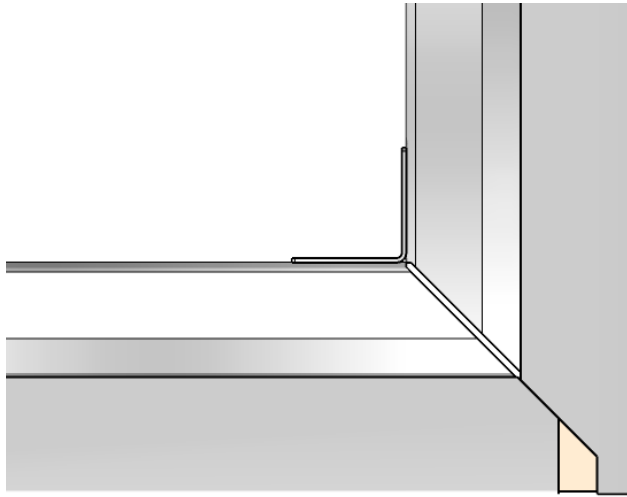

### Step 8

Panels fitted to the two adjacent sides of the Roofbox need to lap on the corners to allow continuation of the insulation



## M5 LIDS Part References

M5-XX-LEC1

M5-XX-LMC1 (x3)

M5-XX-LE1

fit in order A B C D E

5mm gaps between lids

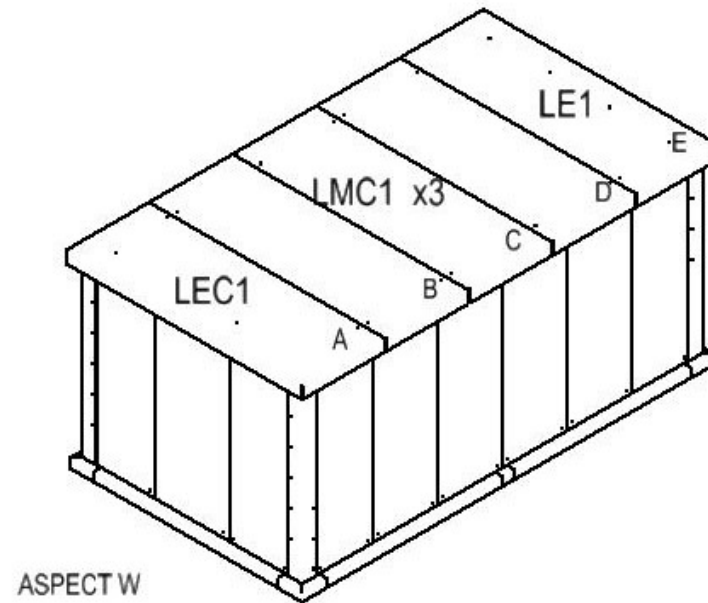

Read in conjunction with drawings

M-0005 (1000h or 1500h) M5- Typical Plans Sections

M-0006 (1000h or 1500h) M5- Typical Elevation

FIXINGS FOR LIDS

DF3-SSA4-PL-HY-S15-5.5x75ppc

## Installing ROOFBOX lids

Roofbox lids are supplied in sets for a specific Roofbox location. Where more than one Roofbox is located on a roof, please ensure that you match up the location number with the right set of lid panels.

Within a set of lid panels, the width of the panels may vary and it is important that the correct lid panels are selected for their specific location on the Roofbox. The location specific installation instructions will advise on where each panel goes on the framework. Roofboxes may only have one lid, however, multiple lids will normally be of equal or similar size.

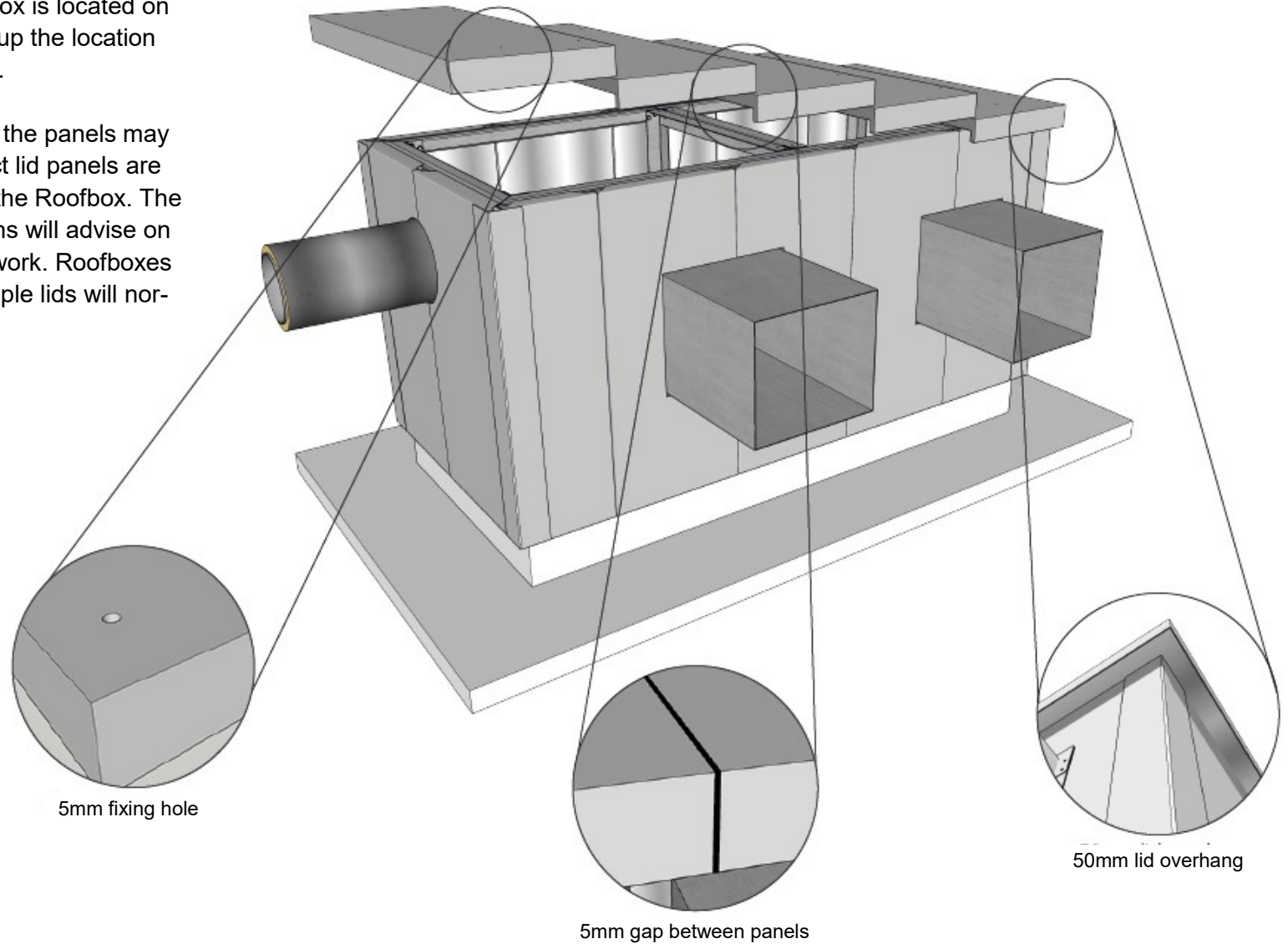

## Installing ROOFBOX lids

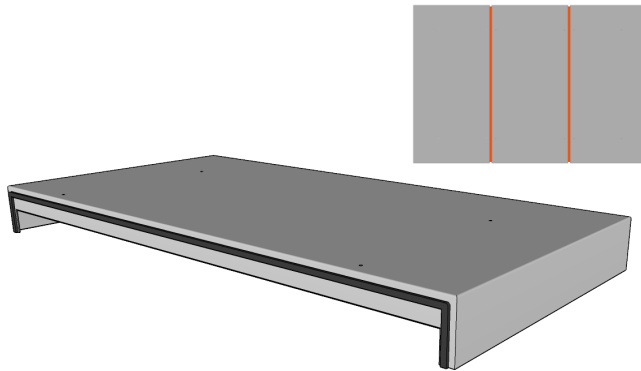

### Step 1

Prior to installation, apply the 10mm compressible foam tape to one side of a lid panel so that all joints have the compressible foam seal. Position the foam tape 10mm back from the face of the lid.

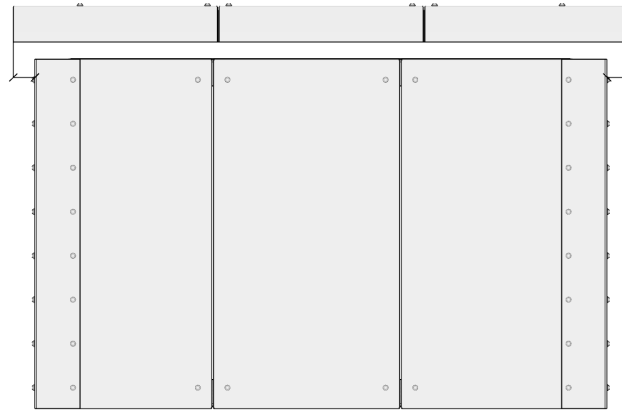

### Step 2

The lid sections should be placed so that there is an equal overhang to the side panels at each side. Ensure that the lids are square to the Roofbox framework and aligned with each other to allow proper sealing upon completion.

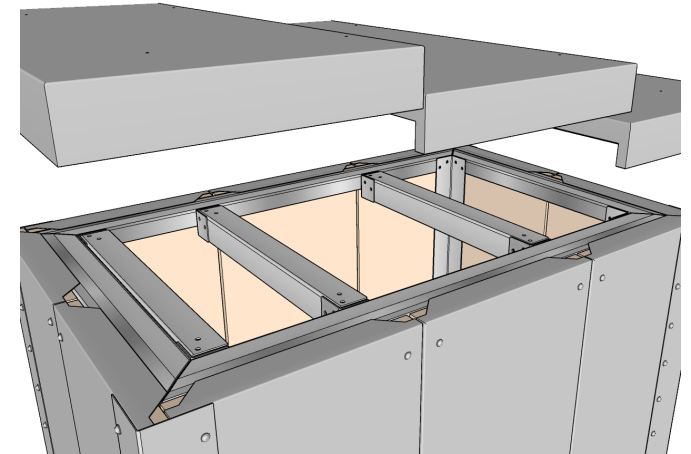

### Step 3

Where there are multiple lids, the joints will usually join on a brace to give support.

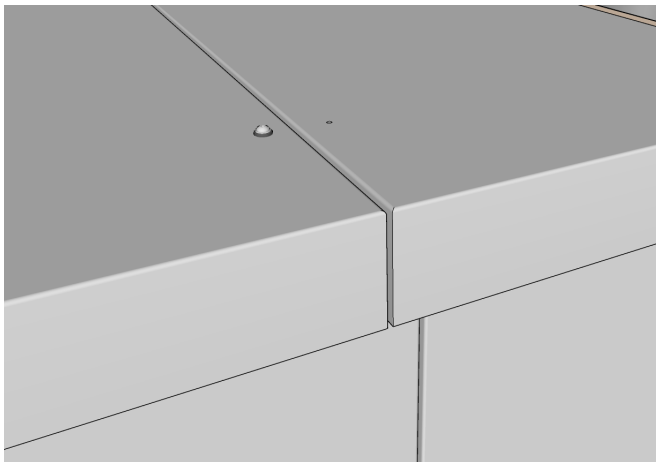

### Step 4

Use a 5mm packing piece to separate the lids during the installation process, this gap will be sealed with a mastic joint later.

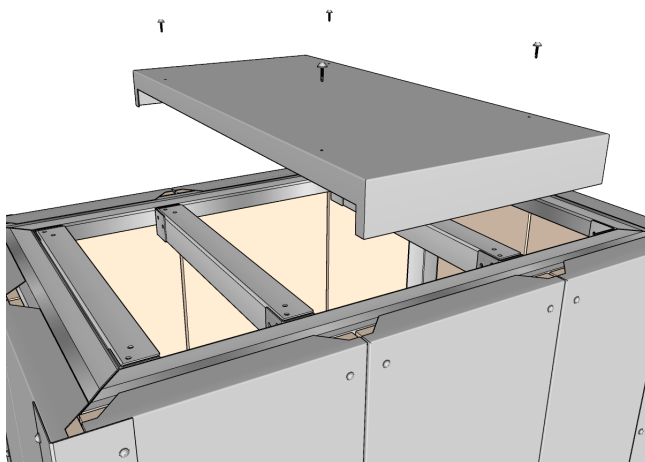

### Step 5

Lids should be fixed to the frame, through the pre-drilled holes, using the self-drilling, self-sealing fixings supplied in the fixing pack.

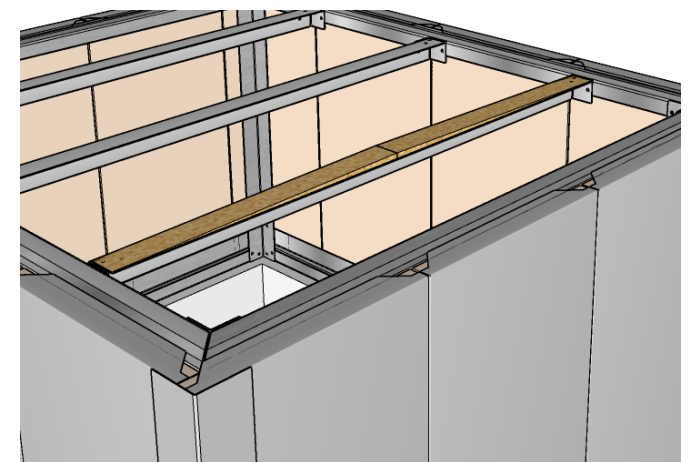

### Step 6

Larger Roofbox cabinets may be supplied with firing pieces, these should be located and secured as shown in the location specific installation instructions.

## Completing the ROOFBOX installation

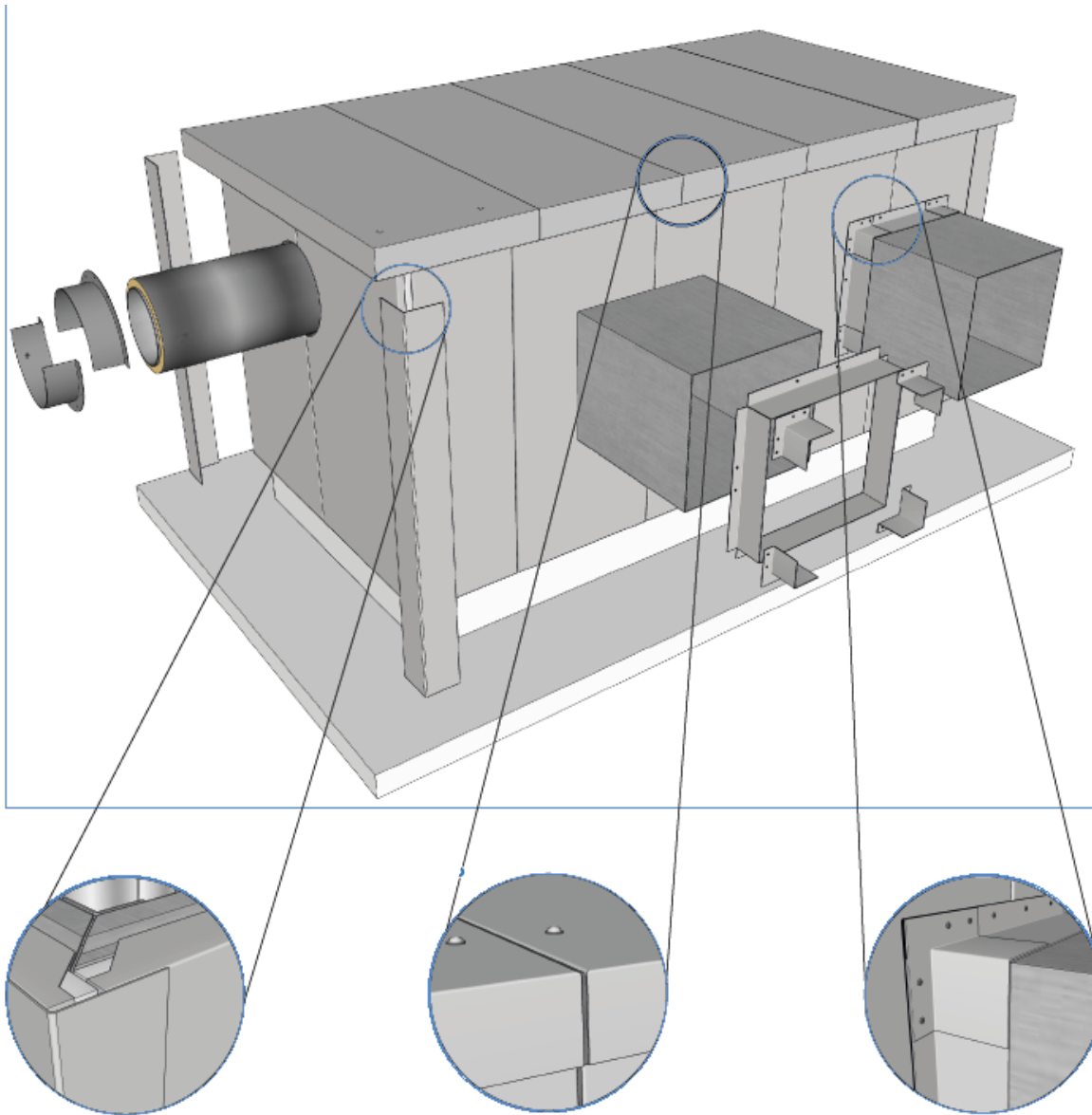

### 1. Corner flashings

These are fixed in position with a colour matched mastic seal and colour matched fixings supplied in the fixing pack. A bead of mastic should be used to seal the flashing to the cabinet at each corner.

### 2. Mastic seal to joints

The joints between the side panels and the joints between the lid panels should be sealed with the colour matched mastic provided in the fixing pack. The mastic should be applied to a minimum depth of 5mm and tooled to a neat flush finish. The mastic seal should be applied by a competent person to achieve a good seal.

### 3. Flashings to service penetrations

The installation process for the different types of service penetrations are included in more detail in the following section. It is important that these instructions are followed to obtain a warranty.

## Weathering details - pipes and cables



### Step 1

Cut or drill the correct size hole for each service penetration. Allow a 5mm tolerance around the services including any insulation. Make good cut edges with touch up paint.

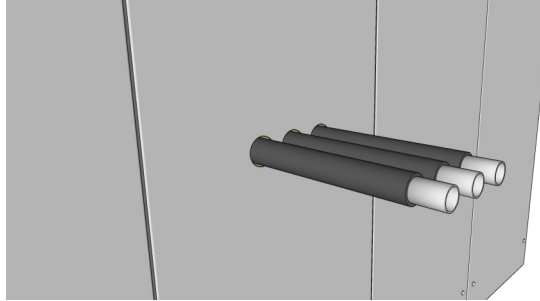

### Step 2

Install the services through the Roofbox panel - ensure that any services penetrating the Roofbox have a fall of at least 1° away from the panel face.

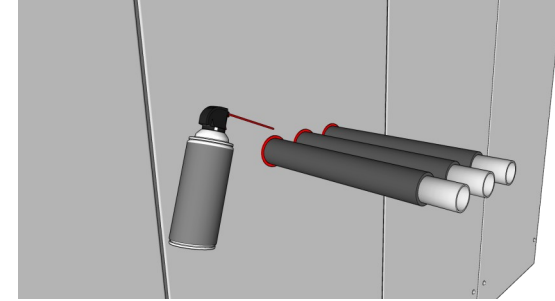

### Step 3

Using a proprietary mastic sealant, or if necessary, a proprietary filler foam, seal between the services and the Roofbox panel.

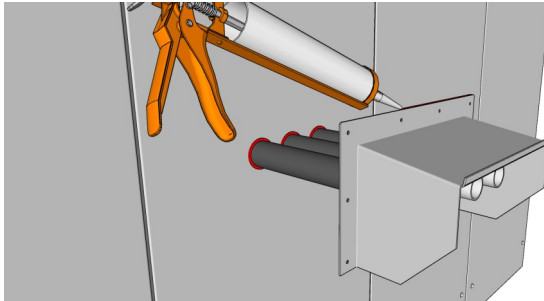

### Step 4

Apply a mastic seal to the weathering hood.

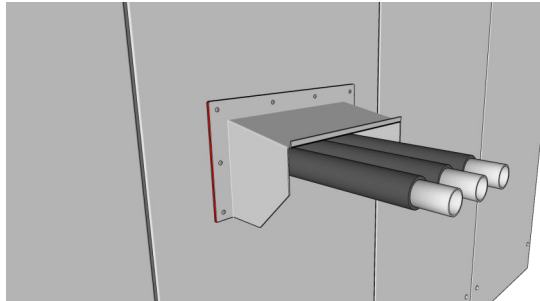

### Step 5

Fix the weathering hood as low as possible over the services to provide weather protection to the service penetrations. Use the 25mm self-sealing fixing screws supplied in the Roofbox fixing pack.

## Weathering details - cable trays and ladders



### Step 1

Cut a letterbox hole as small as possible.  
Make good cut edges with touch up paint.

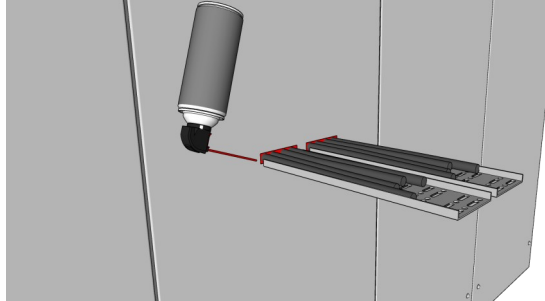

### Step 2

Run the services through the Roofbox panel - ensure a minimum 1° fall away from the Roofbox. Use the Roofbox gap filler to fill the open space in the letterbox holes.

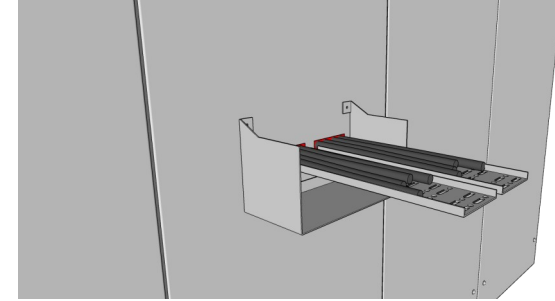

### Step 3

Fit the underhood to the panel, lift as high as possible

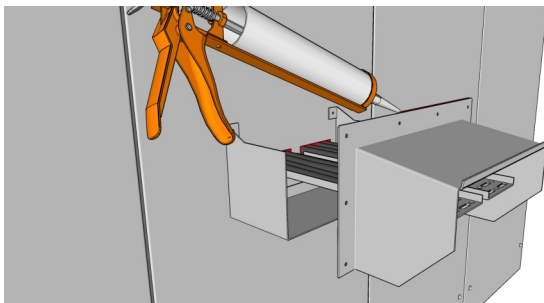

### Step 4

Apply a mastic seal to the weathering hood.

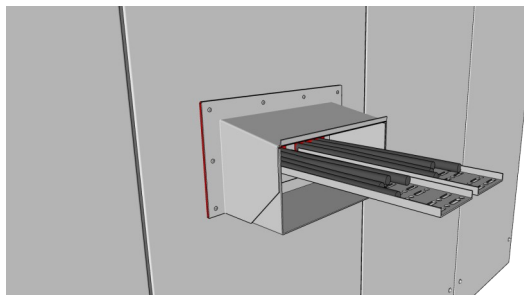

### Step 5

Fix the weathering hood as low as possible over the services to provide weather protection to the service penetration.

## Weathering details - round ducts using circular flashings

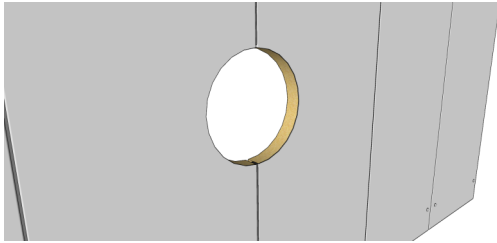

**Step 1**  
Cut installed panels to provide an aperture for the duct allowing 5mm tolerance including any insulation. Make good cut edges with touch up paint

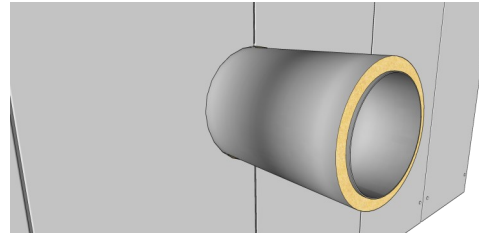

**Step 2**  
Install ductwork including any insulation.

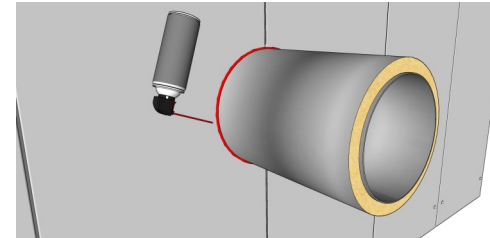

**Step 3**  
Use the Roofbox gap filler or a proprietary mastic to seal the duct to the hole.

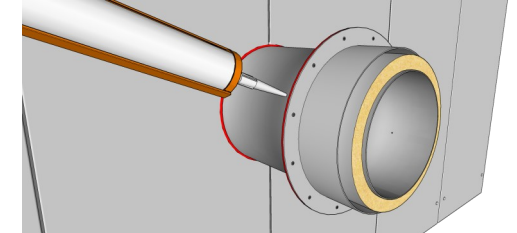

**Step 4**  
Slide the circular flashing over the duct and apply colour matched mastic to the back of the flange.

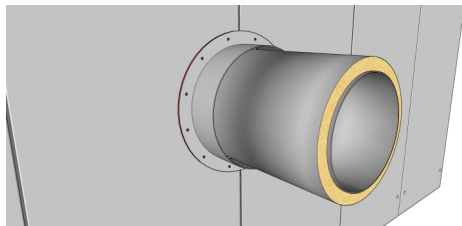

**Step 5**  
Fix the circular flashing to the panels using the 25mm colour matched fixings supplied.

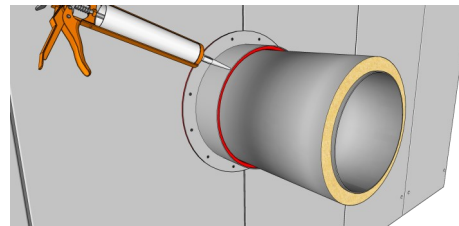

**Step 6**  
Using Roofbox gap filler or a proprietary mastic, make a seal between the duct and the circular flashing.

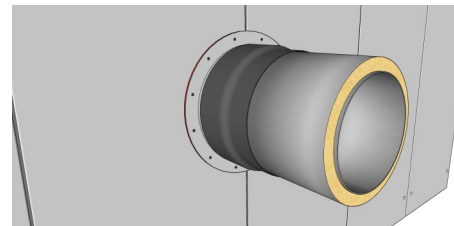

**Step 7**  
Apply a flexible self adhesive flashing sealing to the spigot and to the duct.



## Weathering details - applicable for both ROUND and SQUARE ducts using the two piece flashings

Nicholson recommend seals to be made directly to the services rather than to their covering insulation.

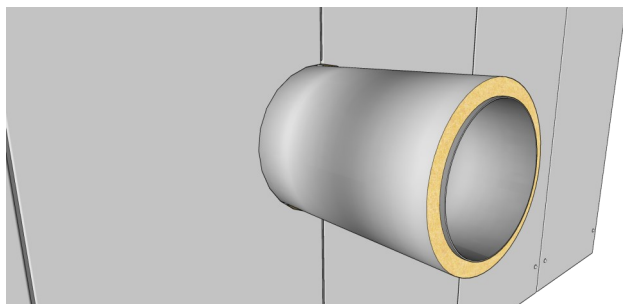

### Step 1

Ensure the panels are cut closely to the duct allowing a 5mm tolerance.

Make good cut edges with touch up paint

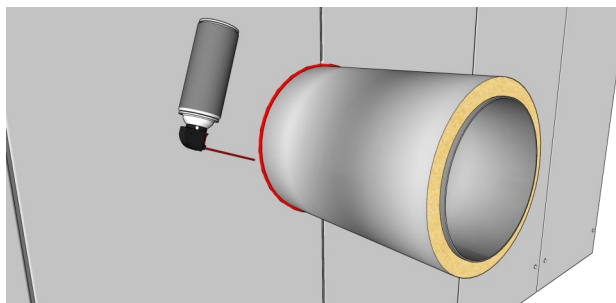

### Step 2

Seal the duct to the panel using the Roofbox gap filler or a proprietary mastic.

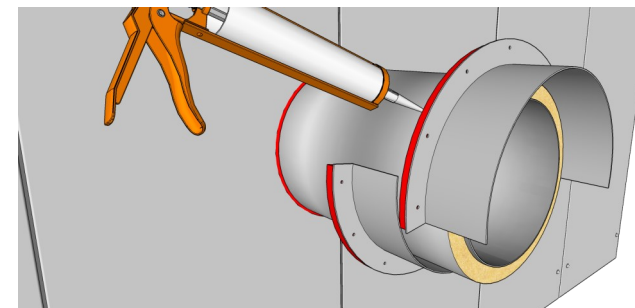

### Step 3

Slide the two halves of the split flashing over the duct ensuring the top part overlaps the lower part. Apply colour matched sealant to the back of the flange.

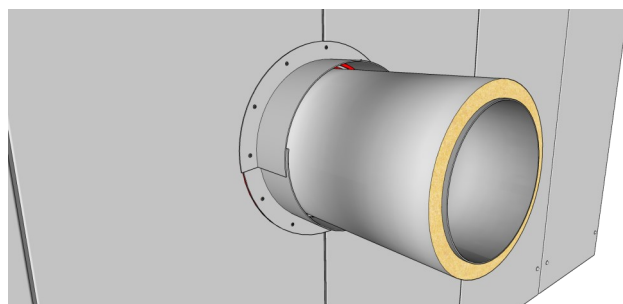

### Step 4

Fix the two parts to the panel using the colour matched fixings supplied. Apply a mastic seal between the two parts where they overlap.

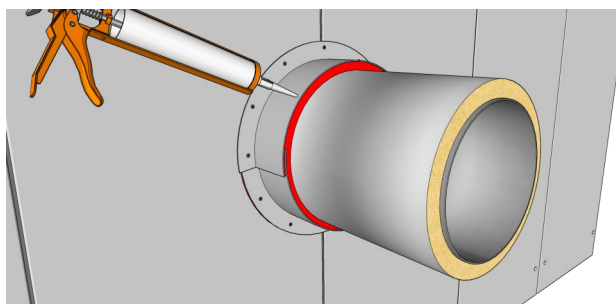

### Step 5

Using Roofbox gap filler or a proprietary mastic, make a seal between the split circular flashing and the duct.

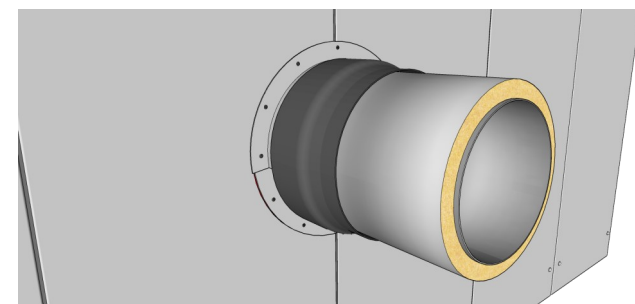

### Step 6

Apply a flexible self adhesive flashing to seal to the spigot and to the duct.

## Weathering details - Square and rectangular ducts using the universal flashing

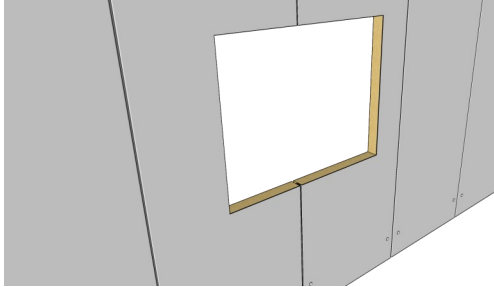

**Step 1**  
Cut the panels to make an aperture for the duct with a 5mm tolerance. Make good the cut edges with touch up paint

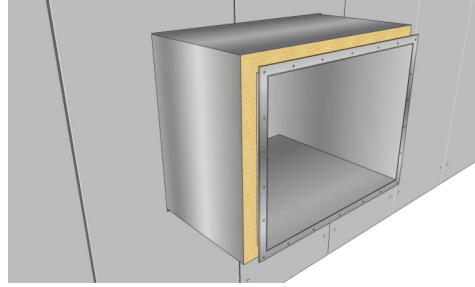

**Step 2**  
Ductwork and insulation if necessary installed through hole in panels.

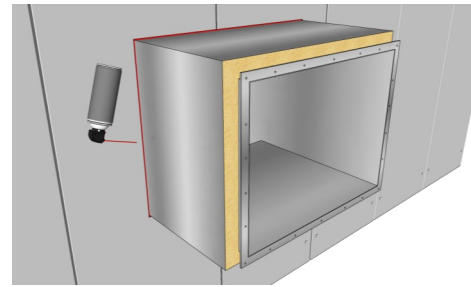

**Step 3**  
Seal between duct and panels using Roofbox gap filler or a proprietary mastic.

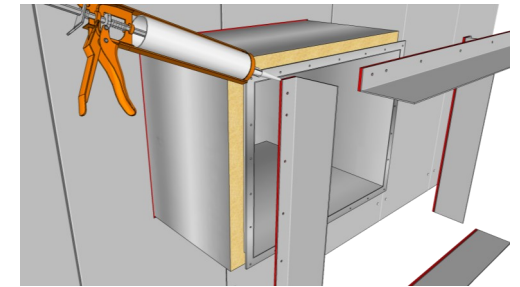

**Step 4**  
Cut the straight lengths to the size of the duct and apply colour matching mastic to the back of the flange.

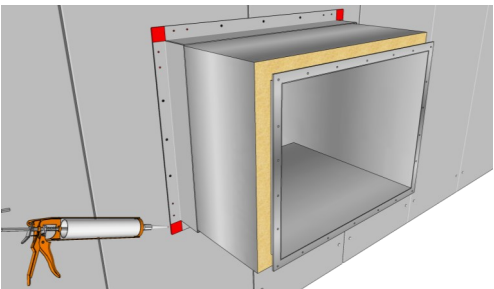

**Step 5**  
Fix the straight lengths to the panels around the duct using the colour matched screws. The lengths should just meet at the corners.

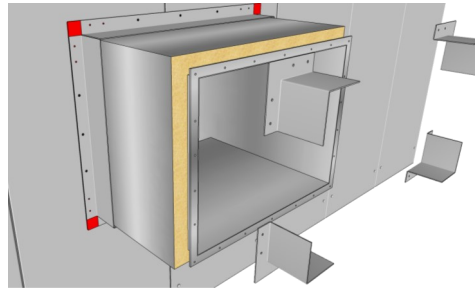

**Step 6**  
Fit the corner pieces using colour matched mastic to seal them. Fix in position with colour matched fixings supplied.

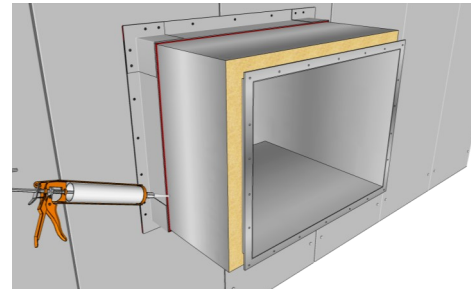

**Step 7**  
Seal between the flashing and the duct using a proprietary sealant.

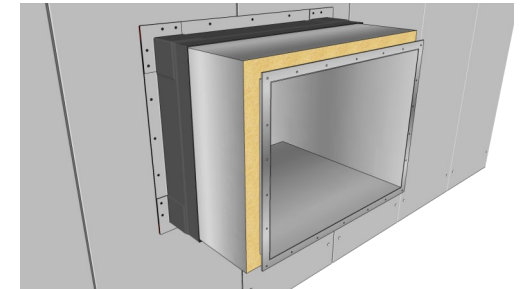

**Step 8**  
Apply a flexible self adhesive flashing over the joint between the universal flashing and the duct.

## Weathering details - Louvre vents

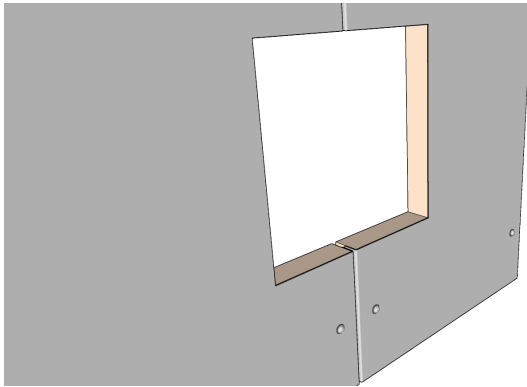

### Step 1

Cut an aperture in the panels suitable for ventilation grille.  
Allow a 5mm margin.  
Make good the cut edges with touch up paint

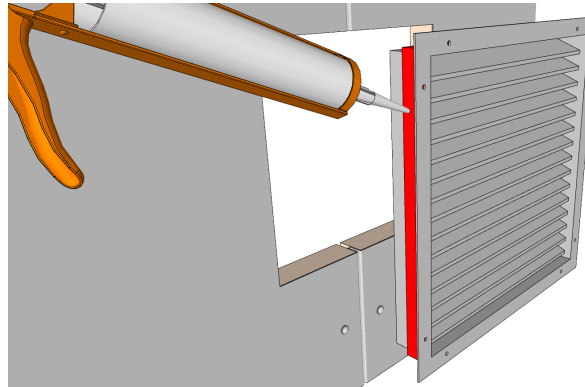

### Step 2

Apply colour matched mastic to the flange of the ventilation grille.

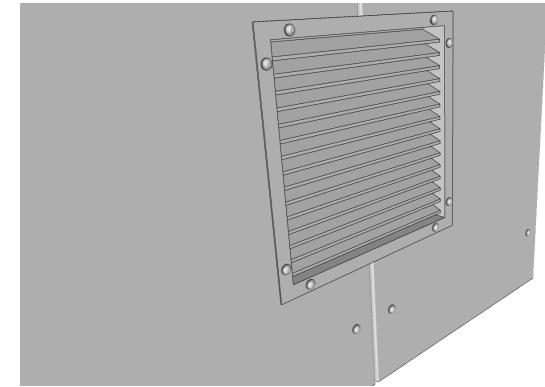

### Step 3

Fix the ventilation grille into the panel using colour matched fixings.

## Weathering details - Access panels

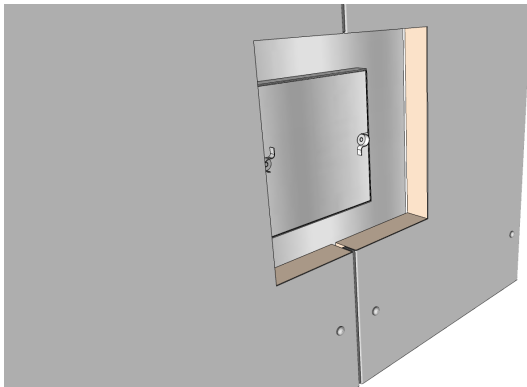

### Step 1

Cut an aperture in the panels suitable for access door.  
Allow a 5mm margin.  
Make good the cut edges with touch up paint

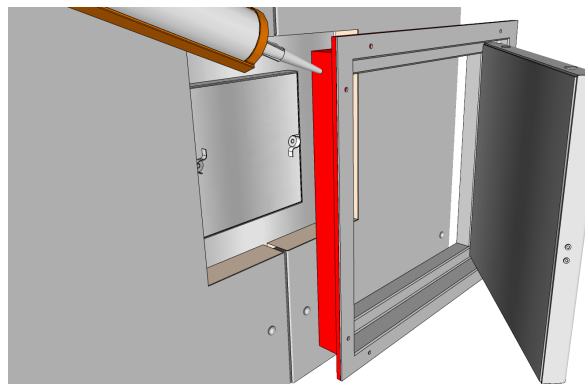

### Step 2

Apply colour matched mastic to the flange of the access door.

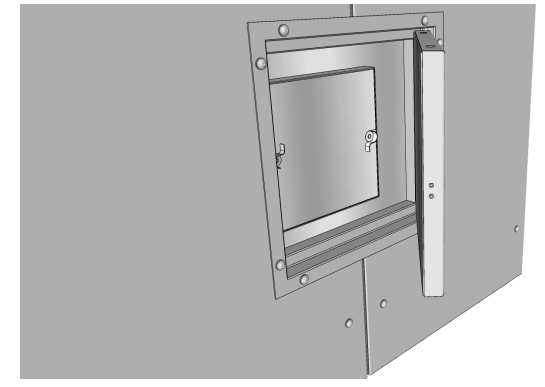

### Step 3

Fix the access door into the panel using colour matched fixings.